

## Description

The Sendyne SIM100MOD is the first high voltage isolation monitoring device for EV/HEVs capable of operating correctly even when the battery is active, and experiencing large voltage variations.

The SIM100MOD continuously monitors the isolation resistance between a vehicle's IT (Isolated Terra) power system and chassis for deterioration of insulation and potentially dangerous levels of leakage current. The SIM100MOD detects not only resistive leakages but also capacitively stored energy that could be harmful to human operators.

Due to a proprietary, patent-pending advanced algorithm, the module is capable of detecting all sources of leakage, including multiple, simultaneous symmetrical and asymmetrical faults, as well as resistive paths between the chassis and points in the battery with the same potential as the chassis. In the case of an insulation fault, the unit identifies the relative position of the fault in relation to the battery's terminals.

Battery-connected  $V_{x1}$  (Vp) and  $V_{x2}$  (Vn) voltage inputs can measure  $\pm 1000$  V in reference to Chassis (0 V). Communications are achieved via an isolated CAN 2.0B interface (500 kbit/s), with an input voltage range of 5 V to 53 V, and a wide temperature range of  $-40$  °C to  $+105$  °C. The module was designed to ISO 6469-3:2011-12 / FMVSS 305.

## Applications

– Monitoring HEV and EV power systems

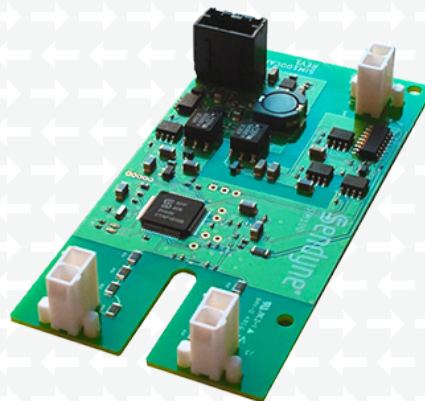

## Features

- Automotive rated
- Isolation monitoring uncertainty  $\pm 5$  %
- Isolated CAN2.0B interface (500 kbit/s)
- Reports battery voltage
- Measures voltage for each battery terminal to chassis
- Measures and reports value of capacitance from each battery terminal to chassis
- Measures and reports modeled leakage resistance per model adapted by safety standards
- Calculates and reports energy stored by total capacitance between battery and chassis
- Reports calculated isolation resistance in  $\Omega/V$
- Continuously measures voltage lines to battery; reports inadequate connections
- Continuously monitors connection to chassis; reports inadequate connections
- Built-in galvanically isolated and intrinsically leakage-safe excitation source

# Sendyne®

Sendyne® Sensing Products Family

## SIM100MOD

*Automotive grade,  
high voltage isolation  
monitor for EVs and HEVs,  
operates even when the  
battery is active*

Sendyne® SIM100MOD Software Home Screen

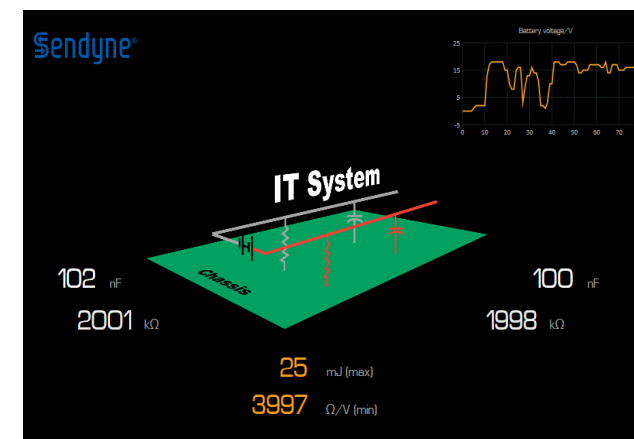

## Ordering Information

Part Number	Description
SIM100CA-MOD	SIM100MOD module
SIM100KIT	SIM100MOD module, CAN to USB protocol converter for PC communications, Windows software and cables

## Product Documentation

### *SIM100MOD Datasheet*

*Detailed description of SIM100MOD functionality; operational, technical and electrical specifications; registers and information on connectors; mechanical specifications.*

### *SIM100 CAN2.0B Protocol Document*

*Detailed description of CAN2.0B protocol registers, general message format, data types, read requests, write requests, manufacturer's data registers, and error flag descriptions. The document also provides a sample SIM100 transaction.*

## Packaging

Assembled circuit board module.

Kit includes module, CAN to USB protocol converter, Windows software and cables.

## Contact

Sendyne Corp.  
250 West Broadway  
New York, NY 10013  
info@sendyne.com  
www.sendyne.com

## Typical Application for the Sendyne SIM100MOD

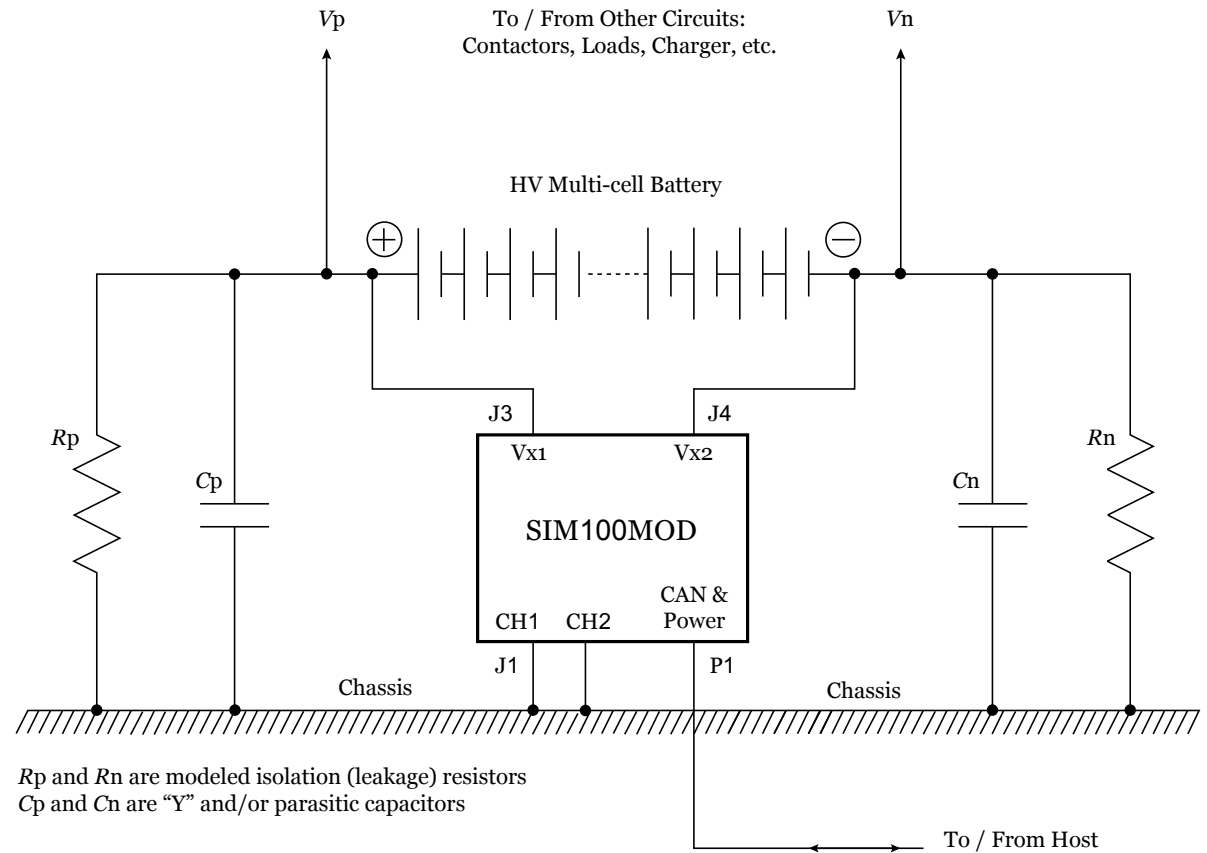

Information in this document is provided in connection with Sendyne products and is believed to be accurate and reliable. However, Sendyne assumes no responsibility for its use, nor for any infringements of patents or other rights of third parties that may result from its use. Specifications are subject to change without notice. No license is granted by implication or otherwise under any patent or patent rights of Sendyne. Sendyne, and the Sendyne logo are trademarks of Sendyne Corporation. Other names and brands may be claimed as the property of others.  
© 2017 Sendyne Corp. All rights reserved.